

## Fitting The Record / Playback Module to Kangoo Models

Version 1

**Applicable to:** *Kangoo Models, 1997-2002 approx.  
(One piece grille)*



*Pre 2002 model*



*Post 2002 model*

**Note:** The process described here is only effective if you can disarm the immobiliser at least once, either by entering the over-ride PIN, or by making a temporary repair to the transponder key system. See the general datasheet for the RPM for further details.

On Kangoo models, the over-ride PIN cannot be entered manually using the master central locking switch. Instead it can only be entered using diagnostic equipment. On these models the PIN is a 4 digit number.

### General

The Record / Playback Module (RPM) needs to be fitted to the immobiliser / central locking control unit. This is mounted on the right hand side of the steering column, and you will need to remove the instrument pack in order to get to it. Connections can usually be made without removing the control unit from the car.

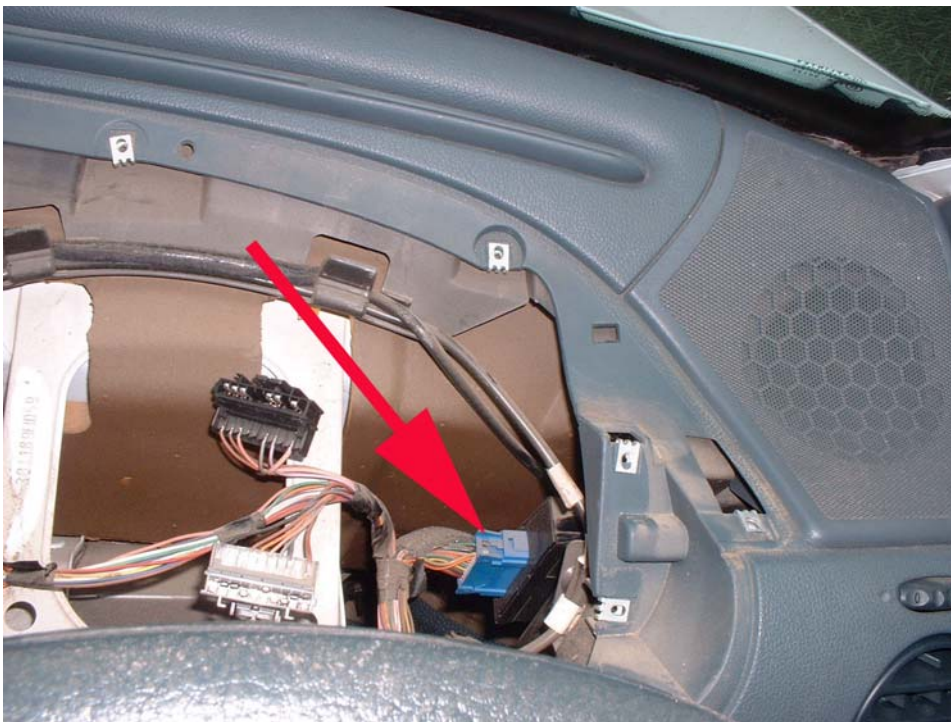

*View from over the top of the steering wheel*

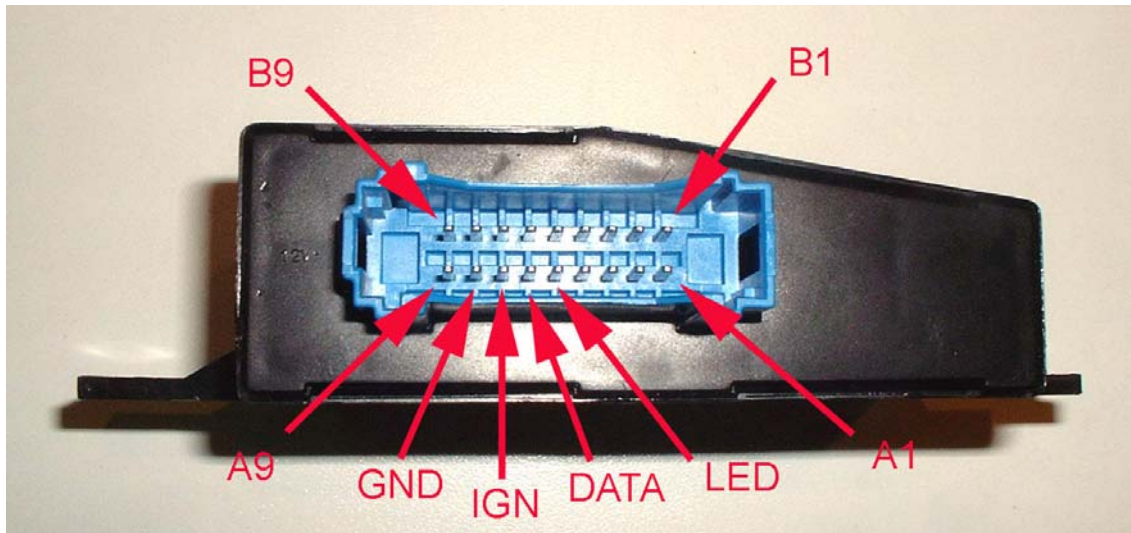

*View looking into connector, showing relevant pins*

**Connections are as follows:**

**Ground:** Black wire on Record / Playback module to Pin A8 on connector (usually a black wire)

**Ignition:** Red wire on Record / Playback module to Pin A7 on connector (usually a yellow wire)

**Data:** Yellow wire on Record / Playback module to Pin A6 on connector (usually a green wire)

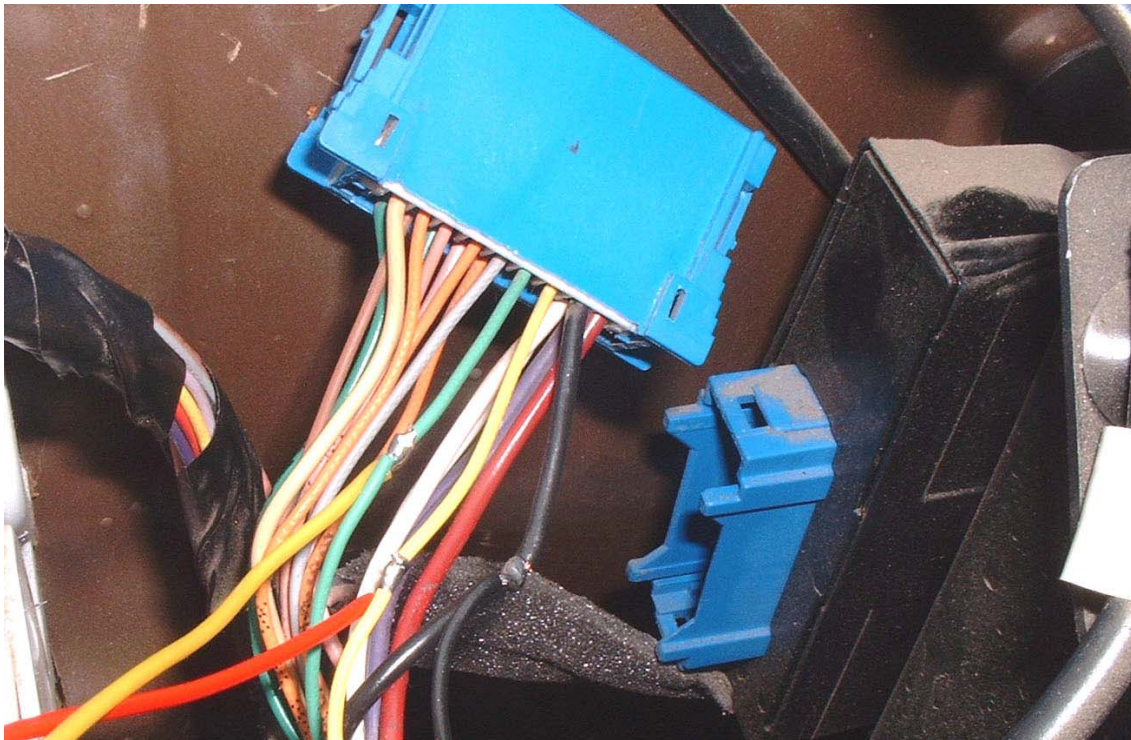

*Typical view of soldered connections, prior to being taped up*

Don't forget to cut the data wire into the immobiliser control unit, once the record phase is over, and the green light has come on on the RPM